



Tote Lid Mount Mixers

OWNERS MANUAL



TL SERIES MIXERS

Warranty

Our products are guaranteed against defective materials and workmanship, we will repair or replace such items as may prove defective at our option. Warranty period is one year on items manufactured by INDCO, except for the MixMaster Series Shakers which carries a two year warranty. On items not manufactured by INDCO, the manufactures warranty applies. All component parts of our products are covered by this warranty, except for normal wear items such as belts or impellers. We cannot be responsible for damage or abuse to equipment caused by improper installation or operation. Warranties can also be voided by unauthorized disassembly of equipment. For warranty repairs, equipment is returned to INDCO at the customer's expense; we will repair and return to customer at our expense. Under no circumstances will we allow labor charges or other expense to repair defective merchandise. This warranty is exclusive and is in lieu of all other warranties, whether express or implied. INDCO shall not be liable for any other damages, whether consequential, indirect, or incidental, arising from the sale or use of its products.

Contents:

	Page:
Model - Drawing Data	2
Safety, General & Receiving.	3
Installation	4
Operation	4
Maintenance	4
Parts List	5,7
Exploded View	6



INDCO, Inc.
4040 Earnings Way
New Albany, IN 47151
phone: 812-945-4383
fax: 812-942-9742
web: www.indco.com

INDCO

Tote Lid Mount Portable Mixer

Model: _____

Date: _____

Serial No.: _____

Order No.: _____

100 - Motor:

200 - Shaft:

Part No.: _____

Diameter _____

HP: _____ RPM: _____

• Total length _____

volts: _____ cycles: _____ phase: _____

• Length exposed _____

frame: _____ enclosure: _____

300 - Impellers:

Diameter _____

Type _____

TL Series

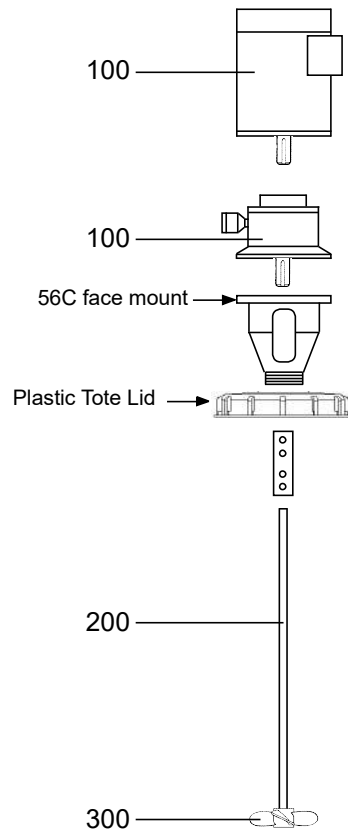

Safety

Please follow the below safety precautions. If there are any questions, please call INDCO at 800-942-4383.

Please read this complete manual before trying to operate your mixer. Failure to follow these instructions could result in serious bodily injury or death.

- Do not touch moving parts while mixer is operating. Do not wear loose-fitting clothes or jewelry around an operating mixer. Keep all hands, feet, clothes, neckties, necklaces and other objects clear of moving parts.
- Never move the unit without a suitable lifting device.
- Have a qualified individual bring power to your unit.
- Always ground the unit. Never use an extension cord.
- Never run the unit in open air.
- Never adjust the speed without the unit running.
- Always lockout the power when working on the unit.

Electric Motor Safety:

Motors should be installed, protected and fused in accordance with latest issue of National Electrical Code, NEMA Standard Publication No. MG 2 and local codes. Frames and accessories of motors should be grounded in accordance with National Electrical Code (NEC) Article 430. For general information on grounding refer to NEC Article 250.

Not all rotating parts are guarded. Keep hands and clothing away from moving parts.

Trained, qualified personnel should make electrical repairs and non-standard connections.

If environment has hazardous combustible fumes present, use only explosion-proof electric motors.

Air Motor Safety:

The air motor is designed to be driven by compressed air and under no circumstances be driven with any other gases. Fluids, particles, solids or any substance mixed with air, particularly combustible substances likely to cause explosions, must not drive air motor.

- Do not drive with flammable or explosive gases or operate unit in an atmosphere containing them.
- Air motor is designed for air only. Do not allow corrosive gases or particulate material to enter motor. Water vapor, oil-based contaminants, or other liquids must be filtered out.
- Do not use a hammer or force coupling or drive pulley onto shaft when installing drive onto air motor. This causes end thrust that could damage air motor.
- Ambient temperature should not exceed 250°F.
- Beware of any exposed and/or movable parts. Proper guards should be in place to prevent personal and/or property damage.
- Solid or liquid material exiting unit can cause eye or skin damage. Keep away from air stream.
- Always disconnect air supply before servicing.
- Do not allow air motor to "run free" at high speeds with no loads. Excessive internal heat build-up, loss of internal clearances and rapid motor damage will result.
- Some models may exceed 85dB(A) sound level. Hearing protection should be worn when in close

General

- Single-phase TEFC models include cord, plug and switch.
- EP models must be wired in the field by the user.
- Air motors include exhaust muffler.

TL - Tote Lid Series

Tote Lid mixers are ideal for agitation of 275 gallon and 330 gallon IBC totes and can be fastened to the 5-1/2" opening in the center of plastic IBC Totes. The TL mixers are light-duty that are great for keeping water-like materials moving inside your tote.

Receiving

Before removing any packing, visually inspect the exterior of the shipment for any sign of damage. Should there be any damage, bring it to the attention of the delivering UPS or truck line and note the same on the receiving ticket. Should there be damage you must place a claim with the truck line. *They are the only ones who will pay for the damage done and you are the only one who can place that claim.*

Installation

Your new mixer is supplied assembled complete except for the impeller(s) and impeller-shaft which have to be fitted to the machine before it's operational.

Mounting Lid - Air or Electric 56C Mount

Mount the mixer to your totes using the plastic tote cap. Thread the tote cap onto the threaded opening to mount.

Shaft & Coupler

To install mixer shaft, back off the set screws as far as possible without removing them. Insert mixing shaft into the coupler as far as it will go. Tighten the set screws firmly to secure the shaft to the coupler.

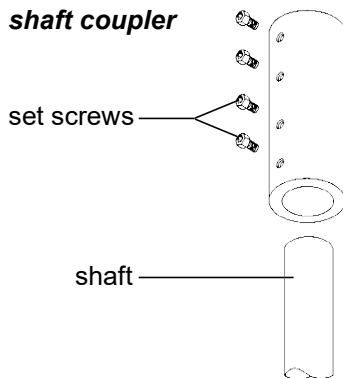

Impellers

The standard impellers are 3-bladed marine style. To install the propeller, back off the set screw(s) as far as possible without removing them. Insert mixing shaft into the bore and tighten the set screw(s) firmly to secure the shaft to the propeller.

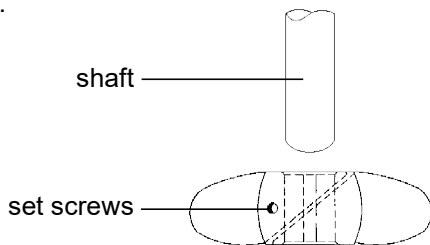

Impeller Placement

For mixers with ONE impeller, mount it 1 to 2 impeller diameters distance off the bottom of mixing container.

For mixers with TWO or more impellers, mount the lowest impeller 1 to 2 impeller diameters distance off the bottom of mixing container. Mount the other impellers 1 to 2 impeller diameters apart. The uppermost impeller should be positioned approximately 1 impeller diameter under the surface of the liquid.

The above guide-lines are "rules of thumb" and may not be the best for your situation. Experimenting with impeller placement may provide your best results.

Operation

Electric Power: Once the electric motor has been wired, check rotation to be sure the mixer shaft is rotating in a clock-wise direction, looking downward into the container.

Air Power: Check to ensure the air valve is in the closed position, then connect air supply. Check rotation to be sure the mixer shaft is rotating in a clock-wise direction, looking downward into the container.

Once the mixer is in the container, it is now safe to operate.

CAUTION:

- ✓ **Never run mixer without a propeller.**
- ✓ **Never run the propeller in open air.**
- ✓ **Never run propeller outside a container.**

Maintenance

Maintaining your mixer is not difficult if you follow these guidelines:

- Keep the mixer clean.
- Check all set-screws and fasteners, tighten as needed.
- Check all wiring on a regular basis and repair as needed.
- Air motor powered units:
 - Keep air supply dry and oil in the lubricator.

Lubrication:

Gear Drive Models:

The gear box contains oil from the factory. The recommended replacement oil is:

- Gearbox models #RPQ1 and RPQ2:
 - Mobil Extra Hecla
 - Shell Oil Omala 680
 - Texaco Meropa 680
 - or equivalent to above
 - For 50°F to 125°F ambient.
 - RPQ1 Oil capacity is 11 ounces.

Parts List - Drive Motors

Item 100	Part No.	Description				
Air Motors	3/4 HP	MTR-3/4-HUB-AIR-CCW N-K202	Hub Mount - 3/4 HP Repair Kit*	(2AM-NCC-16) (2AM-NCC-16)	CCW rotation only	
		MTR-3/4-56C-AIR N-K510	56C Mount - 3/4 HP Repair Kit*	(2AM-NRV-90) (2AM-NRV-90)	bi-rotational	
		HDW-1/4-VALVE HDW-2502-SNB N-AL445 N-AC980	Needle valve, brass - 1/4" Pipe nipple, steel - 1/4" X 2" Muffler, plastic Muffler, metal			
	1.5 HP	MTR-1.5-HUB-AIR N-K205	Hub Mount - 1.5 HP Repair Kit*	(4AM-NRV-22B) (4AM-NRV-22B)	bi-rotational	
		MTR-1.5-56C-AIR N-K206A	56C Mount - 1.5 HP Repair Kit*	(4AM-NRV-50C) (4AM-NRV-50C)	bi-rotational	
		HDW-1/4-VALVE HDW-25-CNG N-AL445 N-AC980	Needle valve, brass - 1/4" Pipe nipple, steel - 1/4" X 7/8" Muffler, plastic Muffler, metal			
	4 HP	MTR-4-56C-AIR N-K208	56C Mount - 4 HP Repair Kit*	(6AM-NRV-11A) (6AM-NRV-11A)	bi-rotational	
		HDW-1/2-VALVE HDW-50-CNG N-AC990	Needle valve, brass - 1/2" Pipe nipple, steel - 1/2" X 1-1/8" Muffler, metal			
	* Repair Kits include: Vanes, shaft seal, o-rings, DE & NDE bearings, body & end cap gaskets.					
	Electric Motors	1/2 HP	MTR-1/2-56C-1-EP	56C, fixed speed	1/2 HP Explosion-Proof	115/230VAC 1-phase
			MTR-1/2-56C-1-TEFC CPG-INLINE-18/3	56C, fixed speed	1/2 HP TEFC Cord 18/3 - 6', plug and in-line ON-OFF switch	115/230VAC 1-phase

Air & Electric Motor
56C Motor Flange
- Direct Drive -

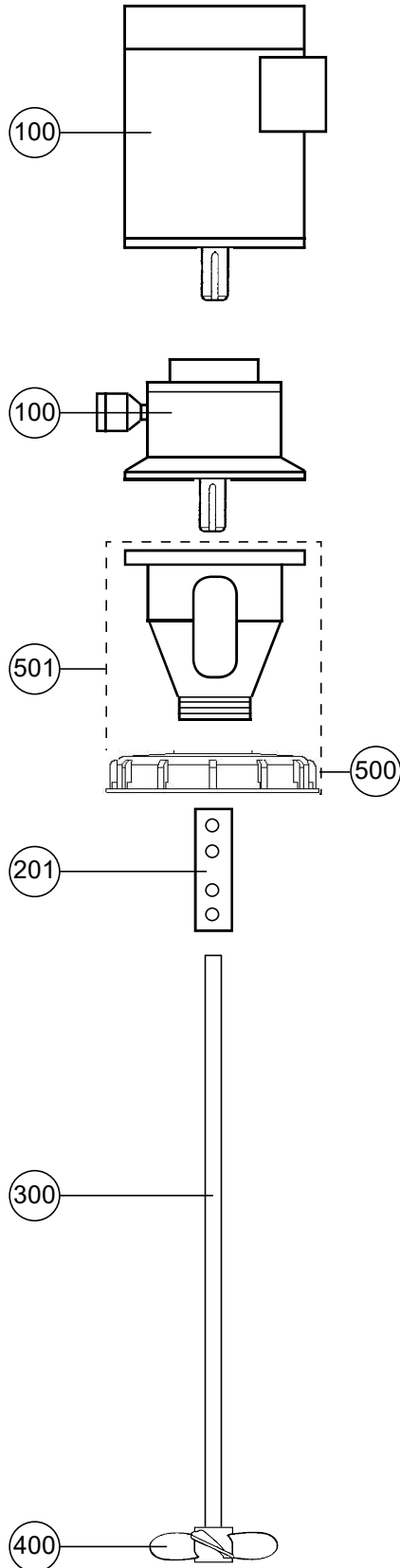

Parts List: TL Series

Item	Description	Part No.	Qty.
100.	Motor, air	see 'Parts List - Drive Motors'	1
100.	Motor, electric	see 'Parts List - Drive Motors'	1
201.	Coupling - shaft, 5/8" bore X 3/4" bore - stainless	CPL-6275	1
300.	Shaft - impeller, 3/4" dia. X 36" long - stainless	SS736	1
300.	Shaft - impeller, 3/4" dia. X 40" long - stainless	SS740	1
300.	Shaft - impeller, 3/4" dia. X 43" long - stainless	SS743	1
400.	Impellers	specify model	1~2
401.	Set screw (not shown)	specify model	2~4
500.	Tote Lid	N-IBC-LID	1